

USE FLY-BY TERMINATION -- PLACE RESISTORS AND CAPS CLOSE TO U21

LOCATE WITHIN 250MILS OF U20

LOCATE WITHIN 250MILS OF U21

Title		
NET FPGA BOARD -- SDRAMs		
Size	Document Number	Rev
C	<Doc>	B
Date:	Monday, May 07, 2007	Sheet 6 of 14

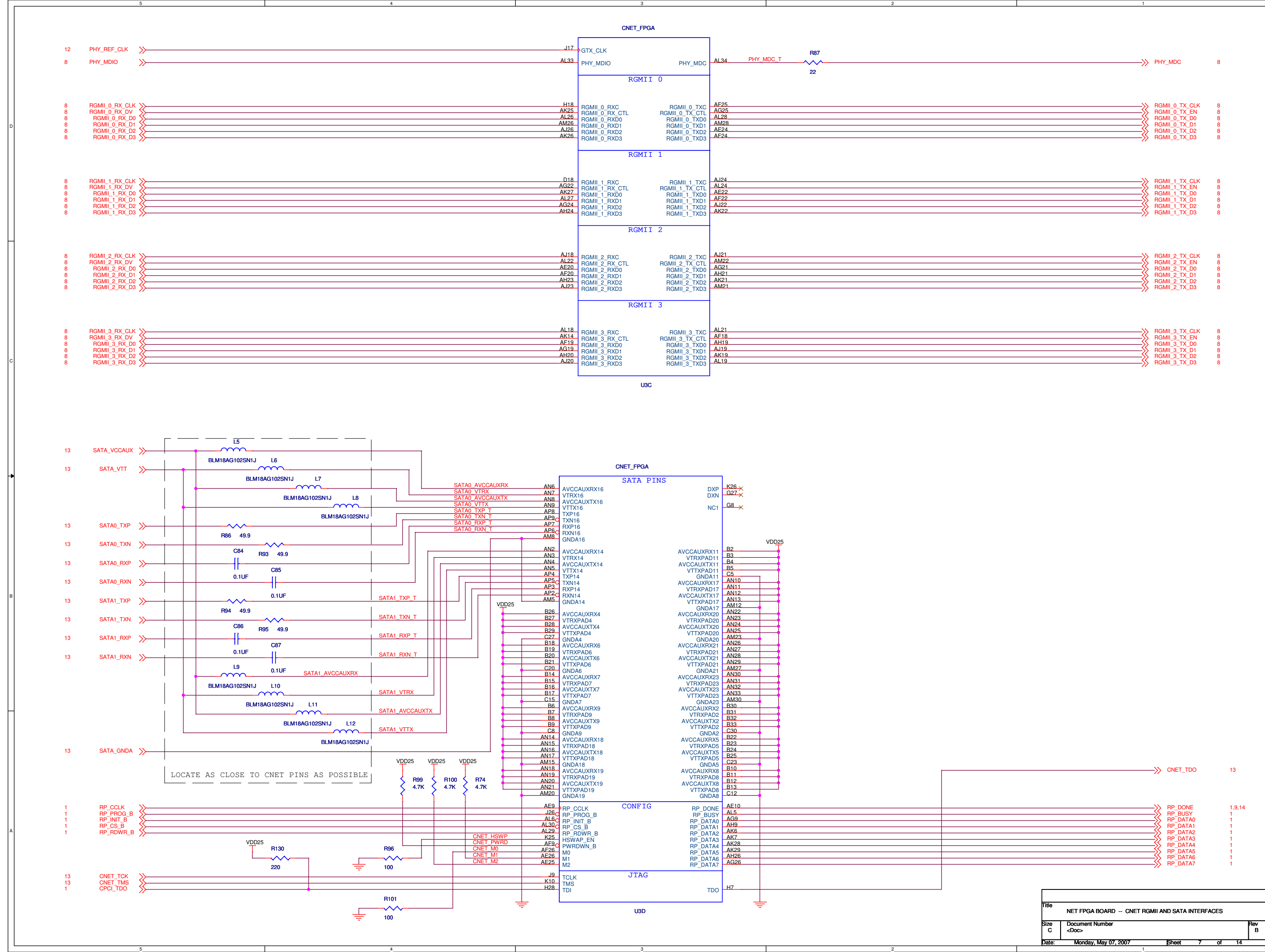

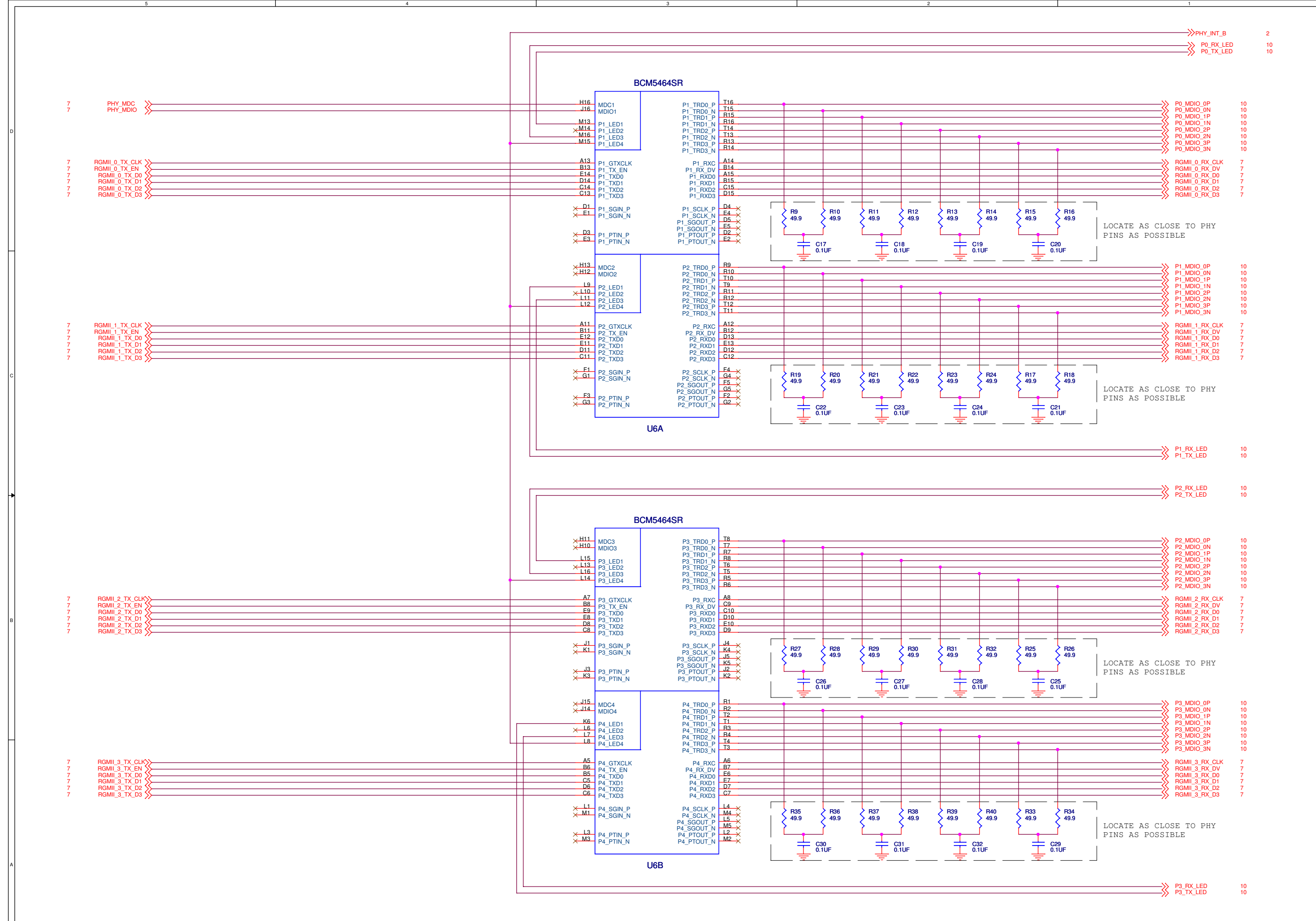

Title		
NET FPGA BOARD -- RGMII PORTS		
Size	Document Number	Rev
C	<Doc>	B
Date:	Monday, May 07, 2007	Sheet 8 of 14

1,7,14 RP_DONE >>

LOCATE AS CLOSE TO PHY PINS AS POSSIBLE

LOCATE WITHIN 250MILS OF U6

LOCATE WITHIN 500MILS OF U6

LOCATE WITHIN 250MILS OF U6

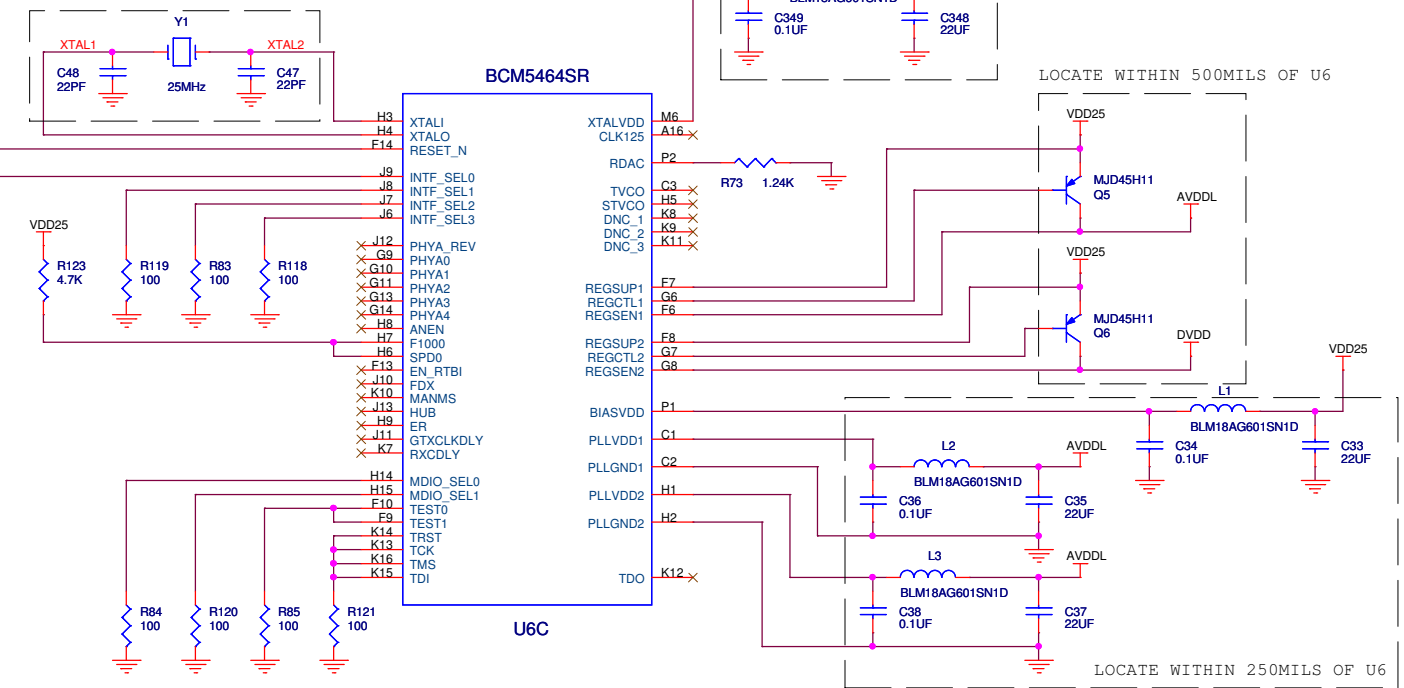

USE FLY-BY TERMINATION

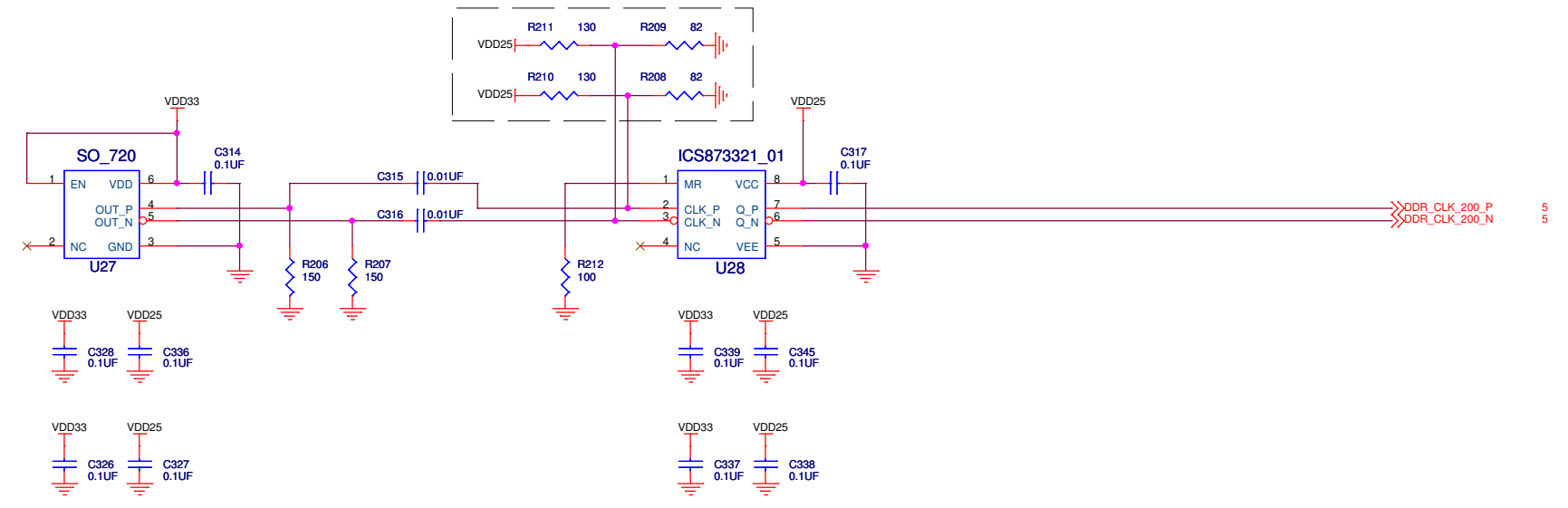

Title		
NET FPGA BOARD -- PHY MODE SETTINGS		
Size	Document Number	Rev
C	<Doc>	B
Date:	Monday, May 07, 2007	Sheet 9 of 14

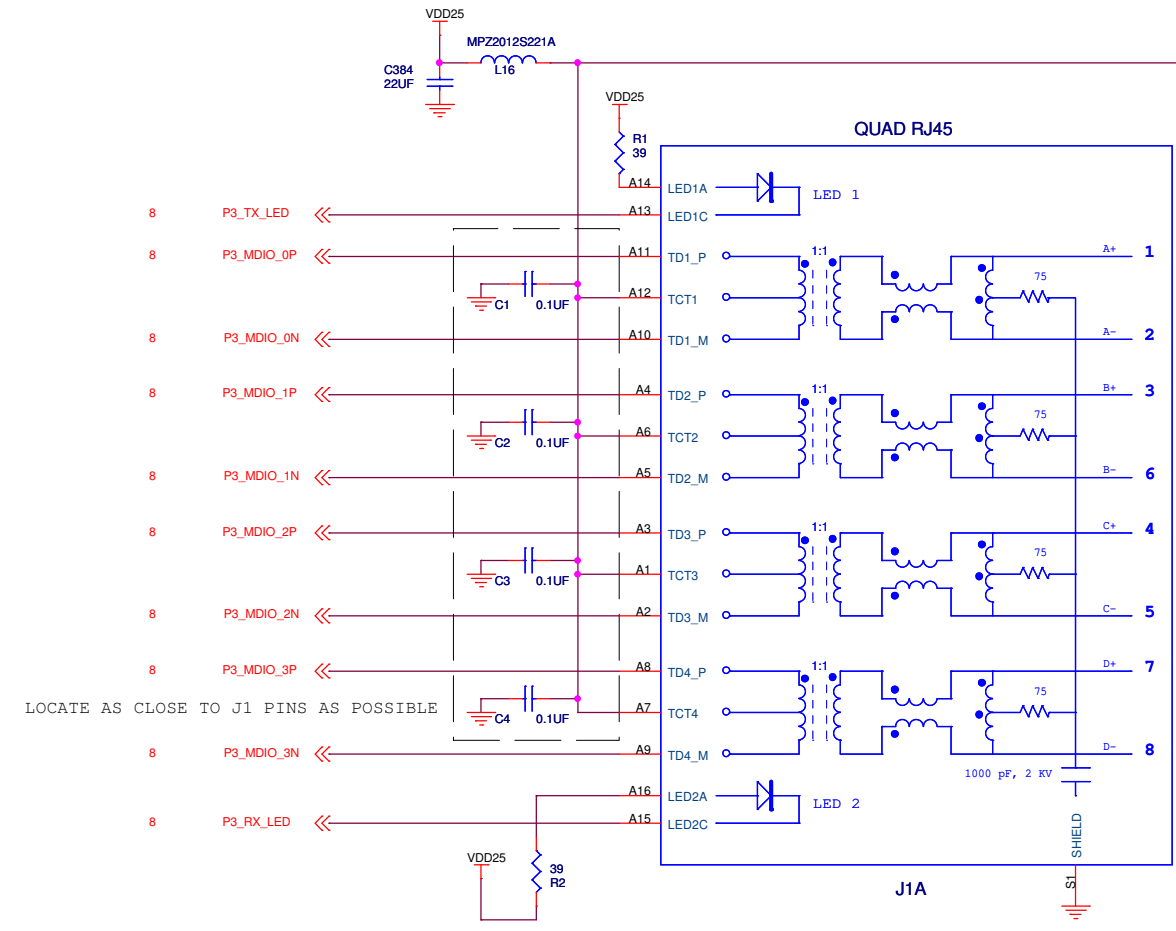

LOCATE AS CLOSE TO J1PINS AS POSSIBLE

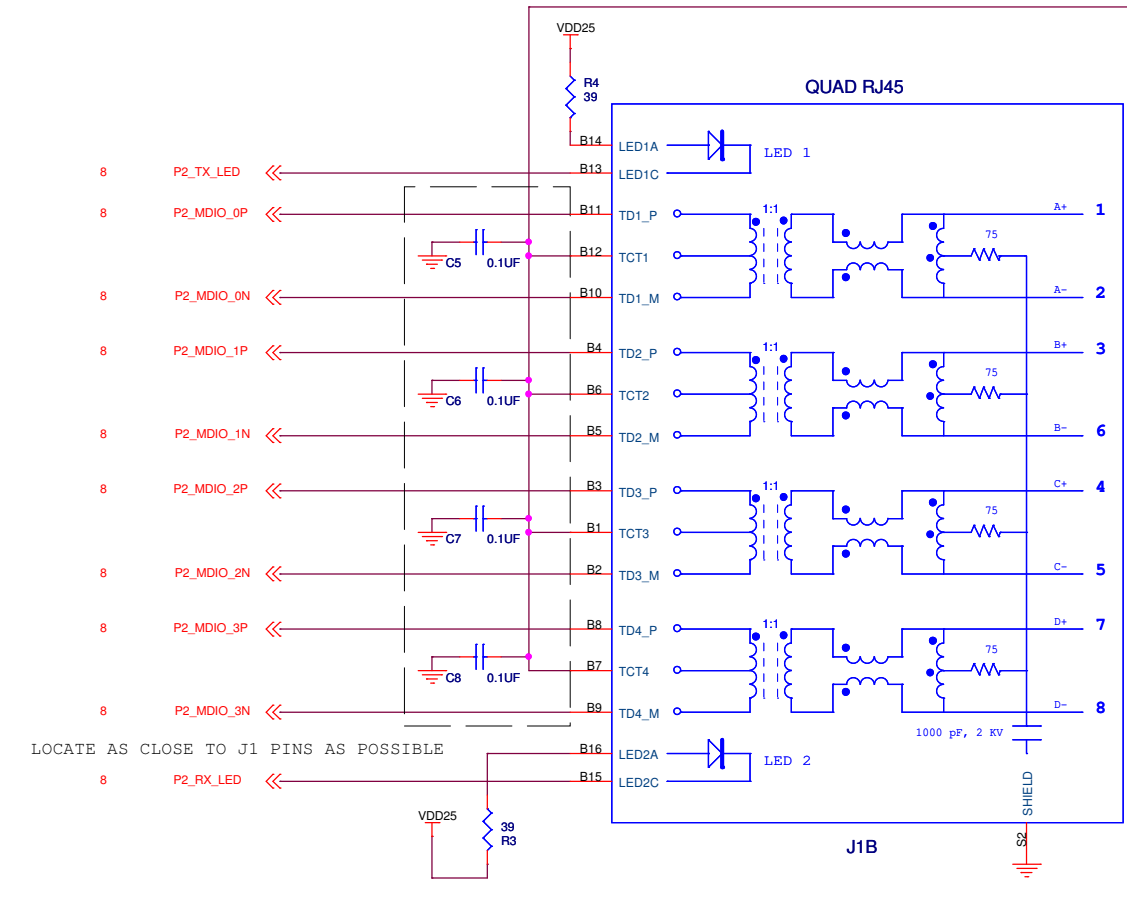
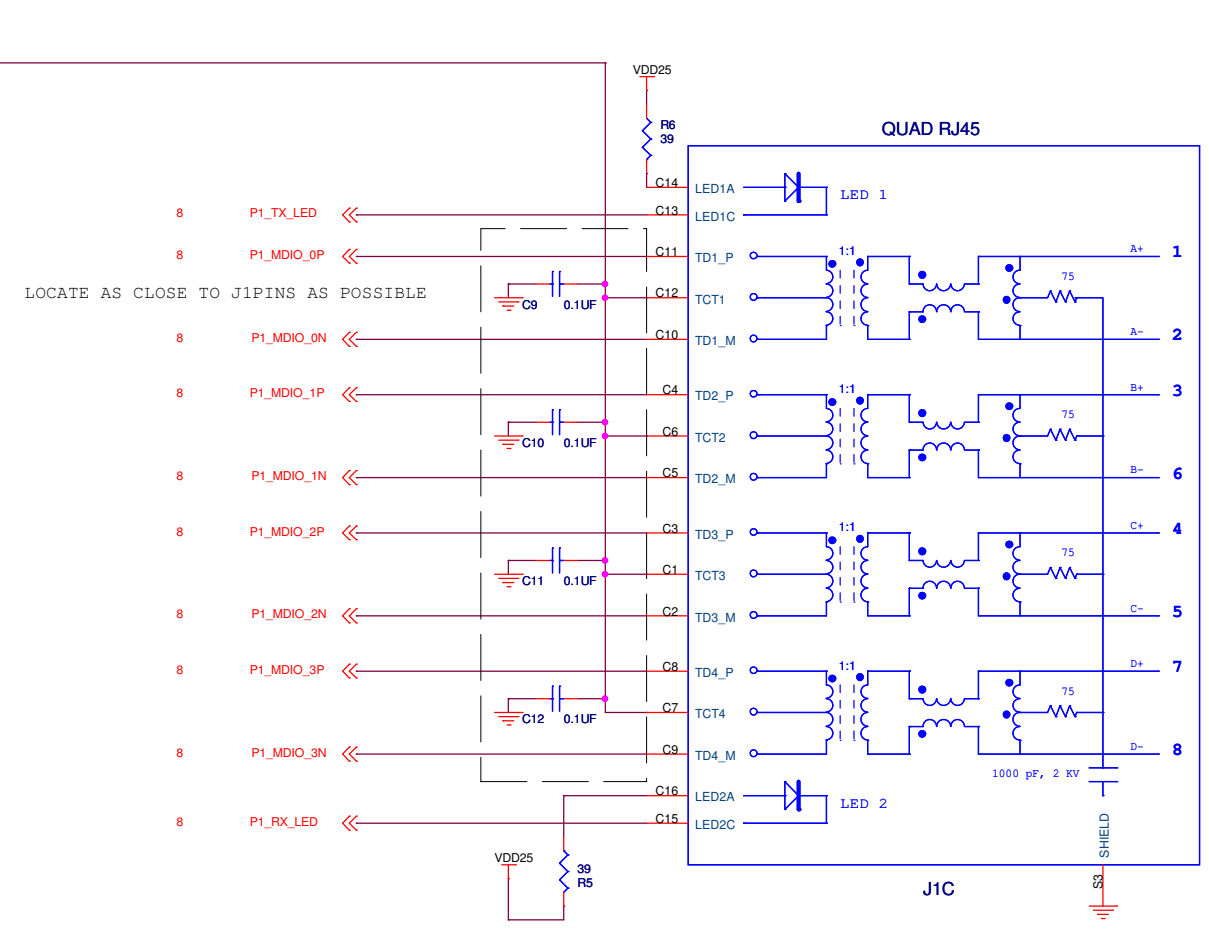

LOCATE AS CLOSE TO J1 PINS AS POSSIBLE

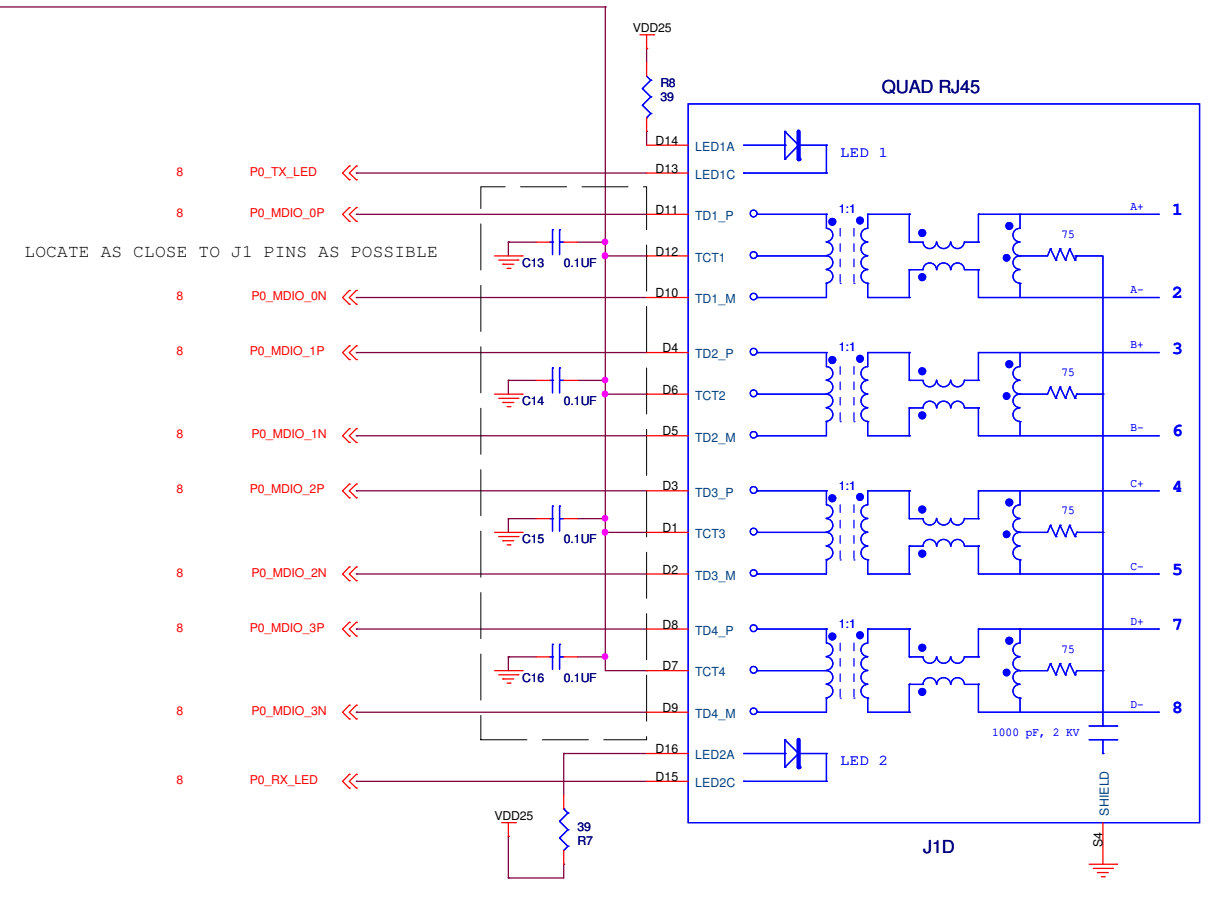

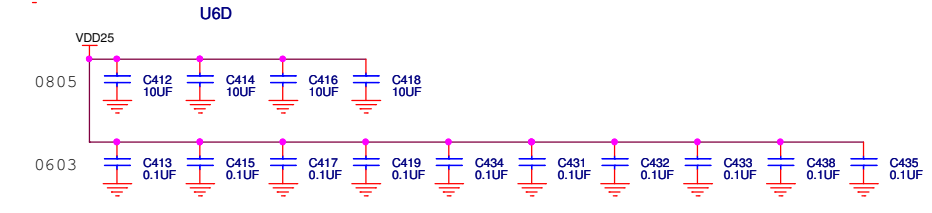
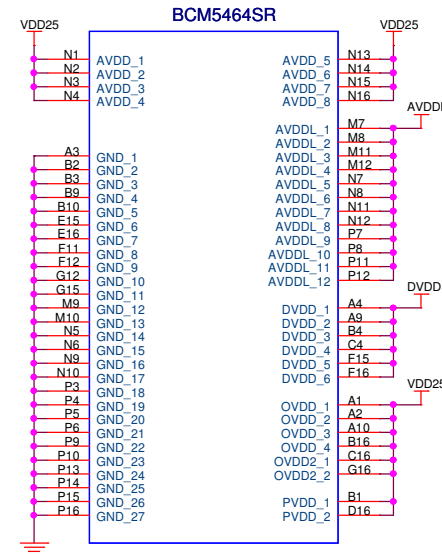

DISTRIBUTE EVENLY ON ALL FOUR SIDES OF U6

PLACE NEAR PIN 1 OF Q5 AND Q6

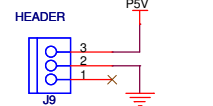

HEADER FOR COOLING FAN FOR PHY

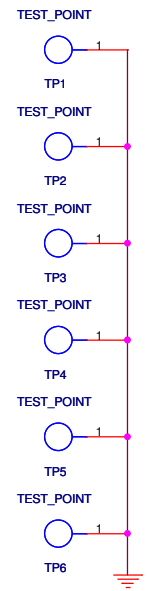

MATCH LENGTHS L1 AND L2 TO WITHIN 50 MILS. MAXIMUM LENGTH: 1000 MILS.

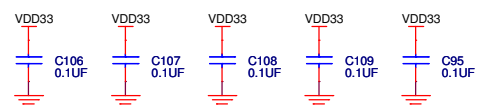
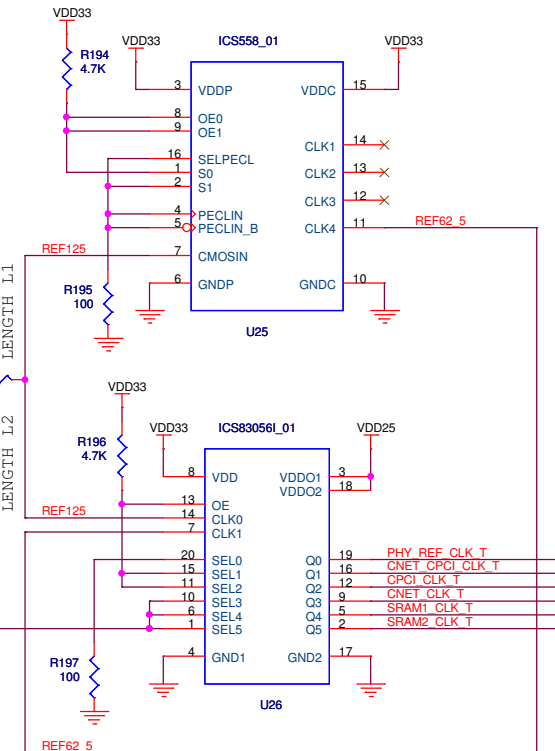
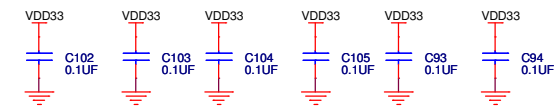
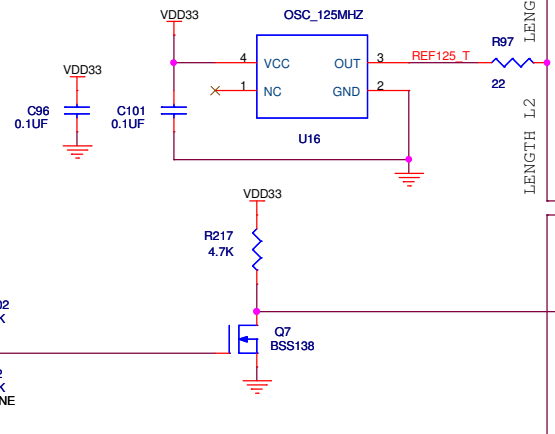

PLACE ONE CAP DIRECTLY FORM PIN 8 TO GND. DISTRIBUTE REMAINING CAPS EVELY AROUND U16

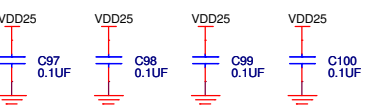

PLACE ONE CAP DIRECTLY ACROSS PINS 3 & 4 AND ONE CAP DIRECTLY ACROSS PINS 18 & 17. DISTRIBUTE REMAINING CAPS EVENLY AROUND UY26

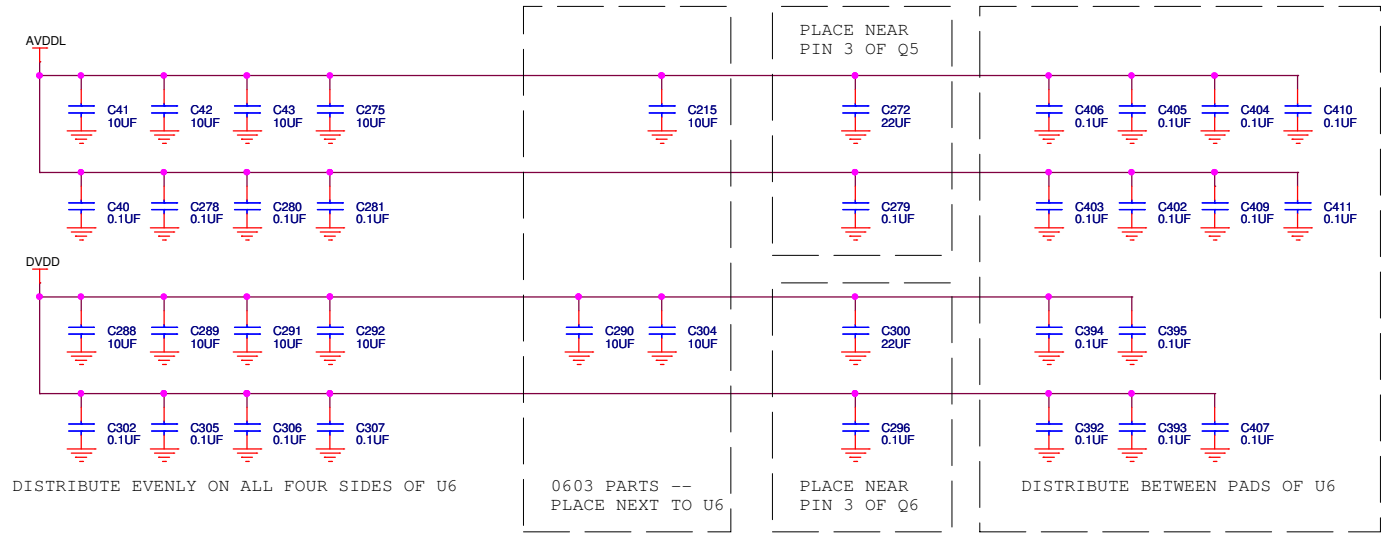

PLACE NEAR PIN 3 OF Q5

DISTRIBUTE EVENLY ON ALL FOUR SIDES OF U6

0603 PARTS -- PLACE NEXT TO U6

PLACE NEAR PIN 3 OF Q6

DISTRIBUTE BETWEEN PADS OF U6

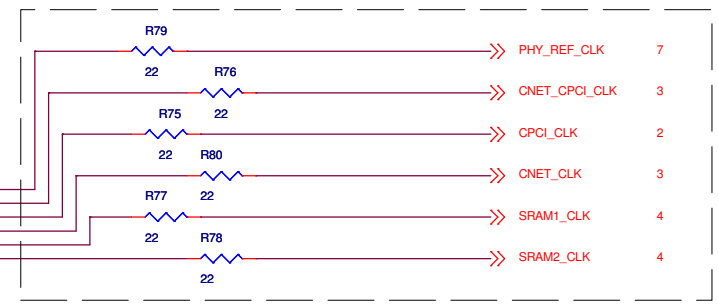
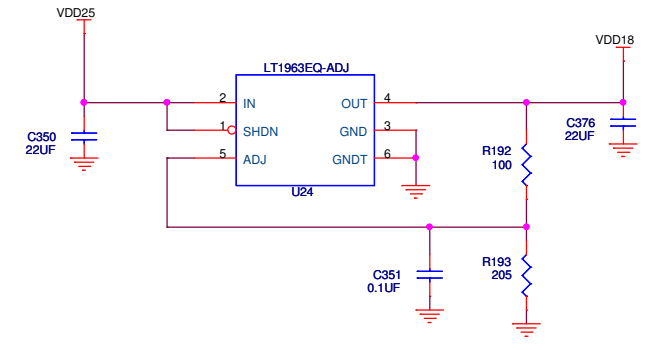

MATCH THE LENGTH OF *_CLK_T + *_CLK TO +/- 0.1"

Title NET FPGA BOARD -- PHY POWER; CLOCK GEN.		
Size C	Document Number <Doc>	Rev B
Date Monday, May 07, 2007	Sheet 12 of 16	

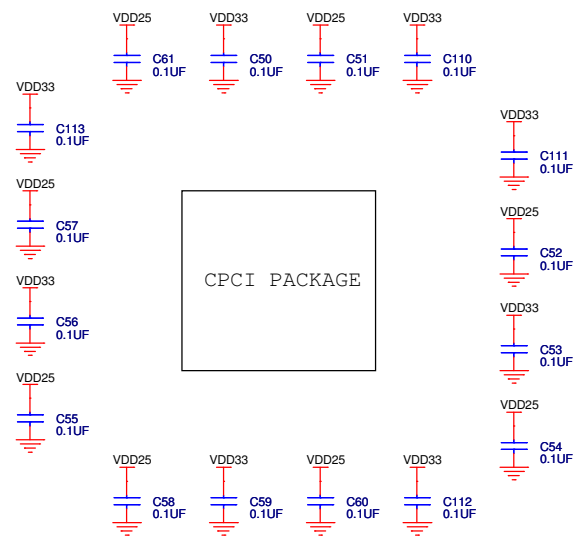
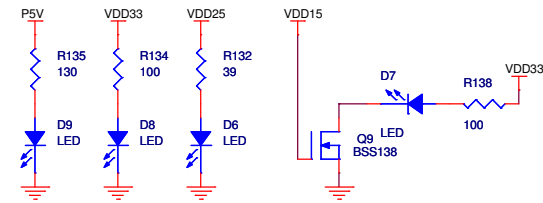
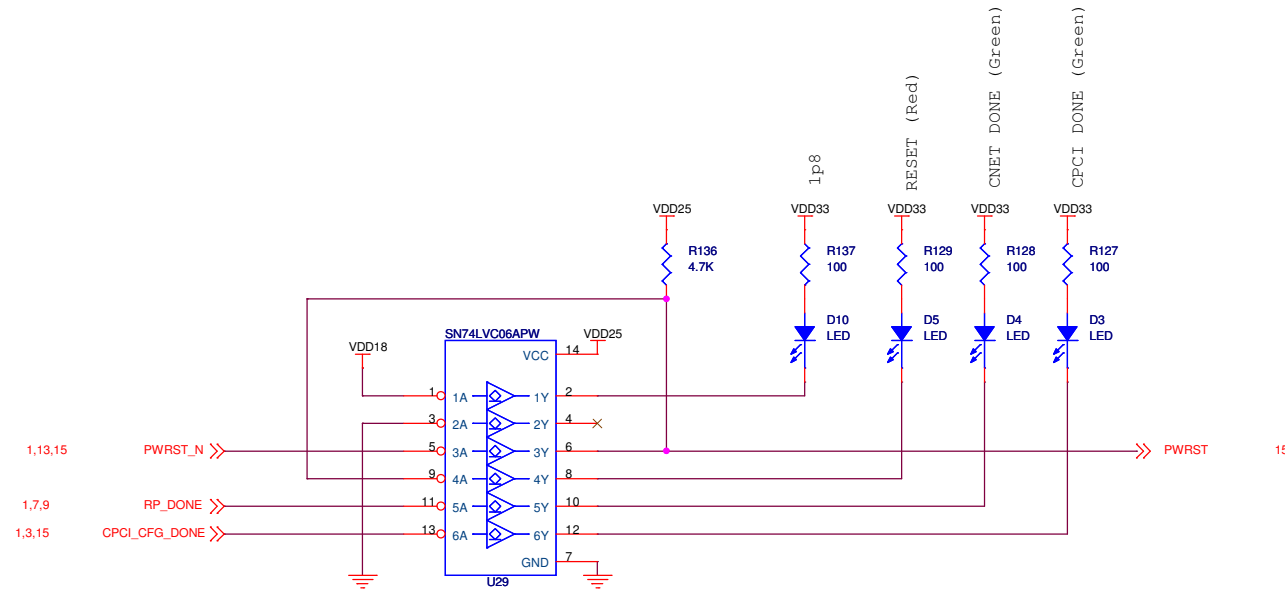

DISTRIBUTE THESE CAPS UNIFORMLY AROUND THE PACKAGE

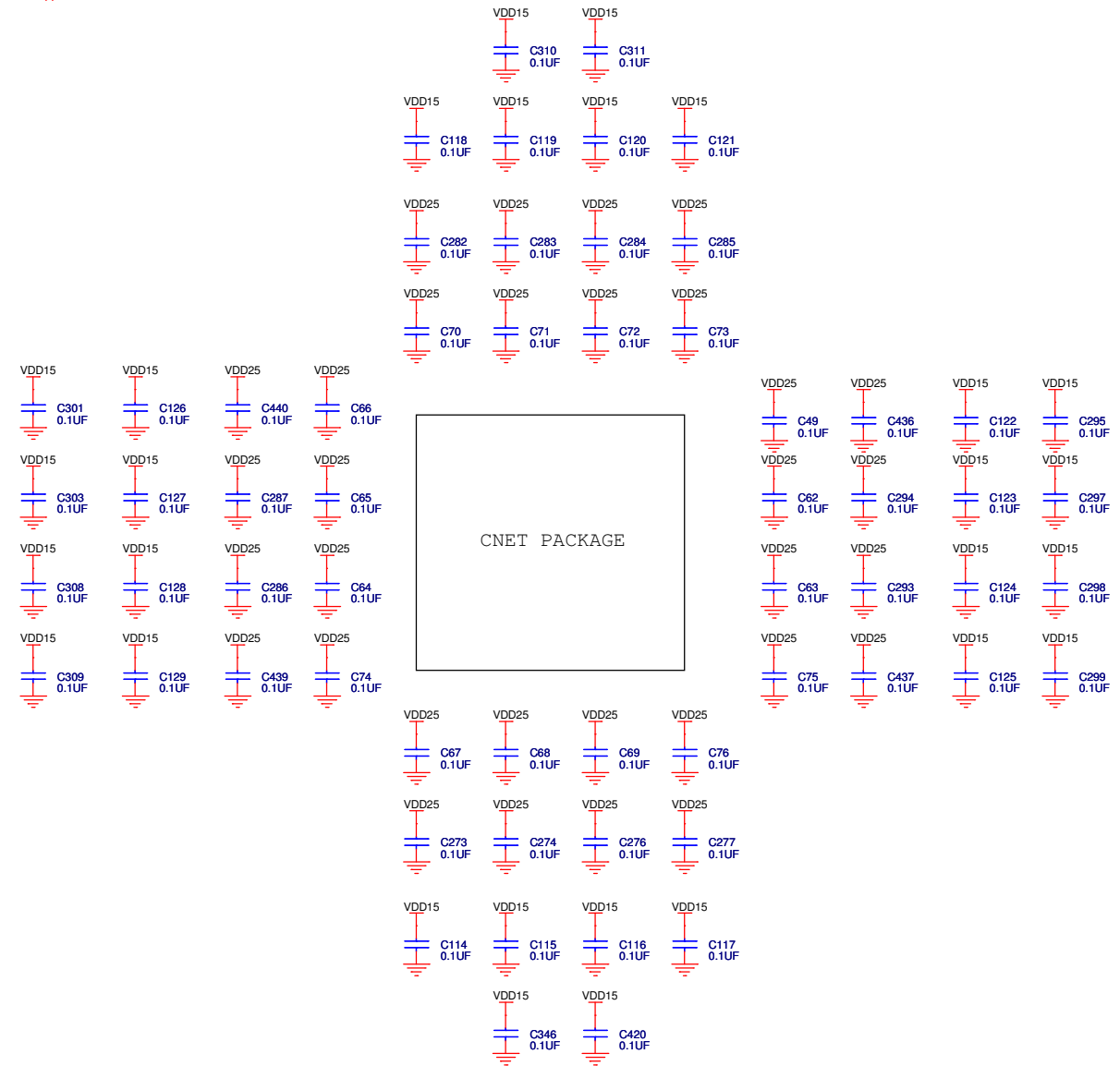

DISTRIBUTE THESE CAPS UNIFORMLY AROUND THE PACKAGE

Title		
NET FPGA BOARD -- LEDS		
Size	Document Number	Rev
C	<Doc>	B
Date:	Monday, May 07, 2007	Sheet 14 of 15

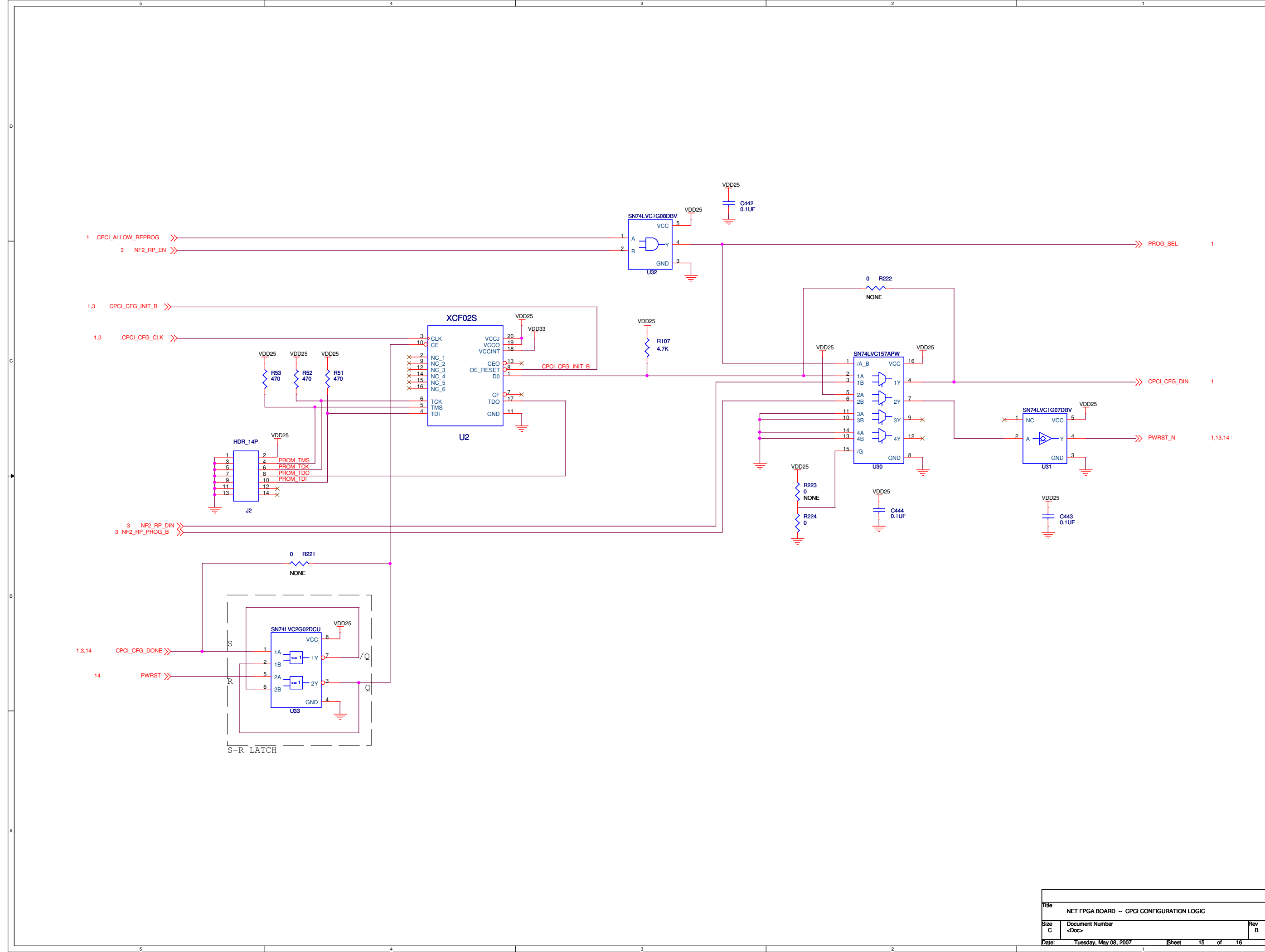

Title		
NET FPGA BOARD -- PCI CONFIGURATION LOGIC		
Size	Document Number	Rev
C	<Doc>	B
Date:	Tuesday, May 08, 2007	Sheet 15 of 16

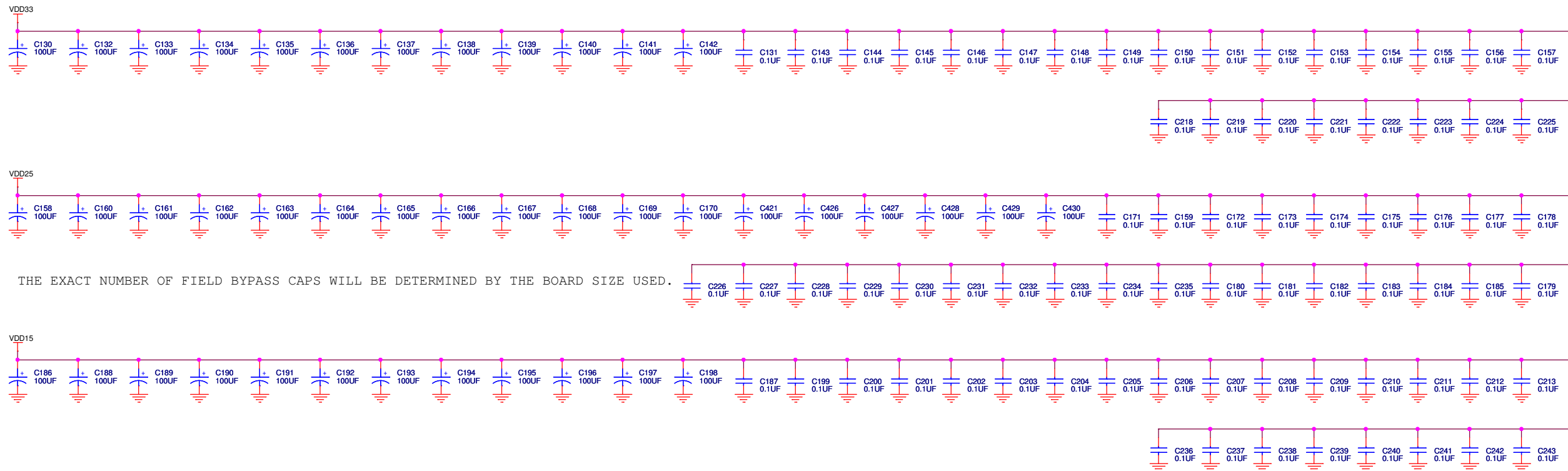

THE EXACT NUMBER OF FIELD BYPASS CAPS WILL BE DETERMINED BY THE BOARD SIZE USED.

CNET_FPGA		
UNUSED PINS		
×A12	UNUSED1	UNUSED61
×A13	UNUSED2	UNUSED62
×A24	UNUSED3	UNUSED63
×A25	UNUSED4	UNUSED64
×A32	UNUSED5	UNUSED65
×A33	UNUSED6	UNUSED66
×A4	UNUSED7	UNUSED67
×A5	UNUSED8	UNUSED68
×AE12	UNUSED9	UNUSED69
×AE13	UNUSED10	UNUSED70
×AE12	UNUSED11	UNUSED71
×AF23	UNUSED12	UNUSED72
×AH12	UNUSED13	UNUSED73
×AL25	UNUSED15	UNUSED74
×AP12	UNUSED16	UNUSED76
×AP13	UNUSED17	UNUSED77
×AP24	UNUSED18	UNUSED78
×AP25	UNUSED19	UNUSED79
×AP32	UNUSED20	UNUSED80
×AP33	UNUSED21	UNUSED81
×C28	UNUSED22	UNUSED82
×C7	UNUSED23	UNUSED83
×D27	UNUSED24	UNUSED84
×AE11	UNUSED25	UNUSED85
×D7	UNUSED26	UNUSED86
×D8	UNUSED27	UNUSED87
×E11	UNUSED28	UNUSED88
×E24	UNUSED29	UNUSED89
×E27	UNUSED30	UNUSED90
×E8	UNUSED31	UNUSED91
×F11	UNUSED32	UNUSED92
×F12	UNUSED33	UNUSED93
×F23	UNUSED34	UNUSED94
×F24	UNUSED35	UNUSED95
×G11	UNUSED36	UNUSED96
×G12	UNUSED37	UNUSED97
×G23	UNUSED38	UNUSED98
×G24	UNUSED39	UNUSED99
×H11	UNUSED40	UNUSED100
×H24	UNUSED41	UNUSED101
×J13	UNUSED42	UNUSED102
×J22	UNUSED43	UNUSED103
×K13	UNUSED44	UNUSED104
×K22	UNUSED45	UNUSED105
×J19	UNUSED46	UNUSED106
×J21	UNUSED47	UNUSED107
×J23	UNUSED48	UNUSED108
×J24	UNUSED49	UNUSED109
×J25	UNUSED50	UNUSED110
×J26	UNUSED51	UNUSED111
×J27	UNUSED52	UNUSED112
×J28	UNUSED53	UNUSED113
×J29	UNUSED54	UNUSED114
×J30	UNUSED55	UNUSED115
×J7	UNUSED56	UNUSED116
×J8	UNUSED57	UNUSED117
×K11	UNUSED58	UNUSED118
×K12	UNUSED59	UNUSED119
×K12	UNUSED60	UNUSED120
×T8	UNUSED326	UNUSED333
×T9	UNUSED327	UNUSED334
×U10	UNUSED328	UNUSED335
×U11	UNUSED329	UNUSED336
×U2	UNUSED330	UNUSED337
×U24	UNUSED331	UNUSED338
×U25	UNUSED332	UNUSED339
×AF10	UNUSED340	UNUSED341

CNET_FPGA		
UNUSED PINS		
×A16	UNUSED121	UNUSED187
×A17	UNUSED122	UNUSED188
×A20	UNUSED123	UNUSED189
×A21	UNUSED124	UNUSED190
×A28	UNUSED125	UNUSED191
×A29	UNUSED126	UNUSED192
×A8	UNUSED127	UNUSED193
×A9	UNUSED128	UNUSED194
×AA25	UNUSED129	UNUSED195
×AA26	UNUSED130	UNUSED196
×AA27	UNUSED131	UNUSED197
×AA28	UNUSED132	UNUSED198
×AA29	UNUSED133	UNUSED199
×AA6	UNUSED134	UNUSED200
×AA9	UNUSED135	UNUSED201
×AB10	UNUSED136	UNUSED202
×AB25	UNUSED137	UNUSED203
×AB26	UNUSED138	UNUSED204
×AB27	UNUSED139	UNUSED205
×AB28	UNUSED140	UNUSED206
×AB29	UNUSED141	UNUSED207
×AB9	UNUSED142	UNUSED208
×AC10	UNUSED143	UNUSED209
×AC25	UNUSED144	UNUSED210
×AC26	UNUSED145	UNUSED211
×AC28	UNUSED146	UNUSED212
×AD10	UNUSED147	UNUSED213
×AD16	UNUSED148	UNUSED214
×M10	UNUSED149	UNUSED215
×AD18	UNUSED150	UNUSED216
×AD19	UNUSED151	UNUSED217
×AD25	UNUSED152	UNUSED218
×AD26	UNUSED153	UNUSED219
×AD27	UNUSED154	UNUSED220
×AD28	UNUSED155	UNUSED221
×AD5	UNUSED156	UNUSED222
×AD6	UNUSED157	UNUSED223
×AD7	UNUSED158	UNUSED224
×AD9	UNUSED159	UNUSED225
×AE14	UNUSED160	UNUSED226
×AE15	UNUSED161	UNUSED227
×AE16	UNUSED162	UNUSED228
×AE17	UNUSED163	UNUSED229
×AE18	UNUSED164	UNUSED230
×AE19	UNUSED165	UNUSED231
×AE21	UNUSED166	UNUSED232
×AE23	UNUSED167	UNUSED233
×AE27	UNUSED168	UNUSED234
×AG17	UNUSED169	UNUSED235
×AG17	UNUSED170	UNUSED236
×AG17	UNUSED171	UNUSED237
×AG17	UNUSED172	UNUSED238
×AG17	UNUSED173	UNUSED239
×AG17	UNUSED174	UNUSED240
×AG17	UNUSED175	UNUSED241
×AG17	UNUSED176	UNUSED242
×AG17	UNUSED177	UNUSED243
×AG17	UNUSED178	UNUSED244
×AG17	UNUSED179	UNUSED245
×AG17	UNUSED180	UNUSED246
×AG17	UNUSED181	UNUSED247
×AG17	UNUSED182	UNUSED248
×AG17	UNUSED183	UNUSED249
×AG17	UNUSED184	UNUSED250
×AG17	UNUSED185	UNUSED251
×AG17	UNUSED186	UNUSED252
×U8	UNUSED300	UNUSED313
×U9	UNUSED301	UNUSED314
×V10	UNUSED302	UNUSED315
×V11	UNUSED303	UNUSED316
×V2	UNUSED304	UNUSED317
×V24	UNUSED305	UNUSED318
×V25	UNUSED306	UNUSED319
×V26	UNUSED307	UNUSED320
×V27	UNUSED308	UNUSED321
×V9	UNUSED309	UNUSED322
×W10	UNUSED310	UNUSED323
×W11	UNUSED311	UNUSED324
×L10	UNUSED312	UNUSED325
×L10	UNUSED313	UNUSED326
×L10	UNUSED314	UNUSED327
×L10	UNUSED315	UNUSED328
×L10	UNUSED316	UNUSED329
×L10	UNUSED317	UNUSED330
×L10	UNUSED318	UNUSED331
×L10	UNUSED319	UNUSED332
×L10	UNUSED320	UNUSED333
×L10	UNUSED321	UNUSED334

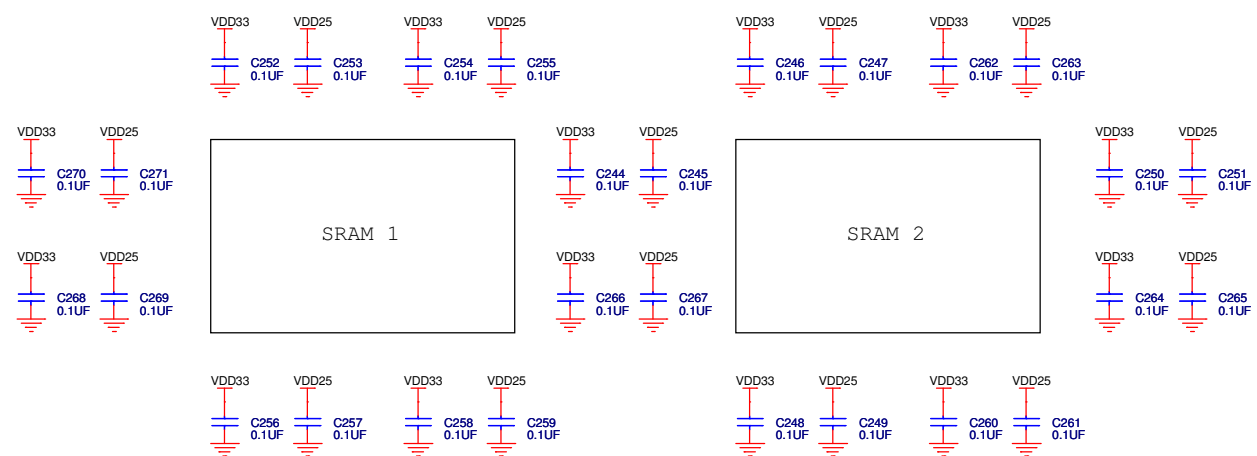

PLACE BYPASS CAPS AROUND SRAMS AS SHOWN